

DATA SHEET

SKY13488-31: 0.7 to 2.7 GHz SP12T MIPI® Antenna Switch Module

Applications

- 2G/3G/4G multimode cellular handsets (LTE, UMTS, CDMA2000, EDGE, GSM, TDD-LTE, TD-SCDMA)
- Embedded data cards

Features

- Dedicated Band 7 TRX ports: 0.8 dB insertion loss @ 2.7 GHz
- High isolation and linearity
- Broadband frequency range: 0.7 to 2.7 GHz
- Twelve linear TRX ports
- Integrated low and high band GSM harmonic filters
- Integrated MIPI interface
- External MIPI select pin to enable multiple trigger controls
- Small MCM (20-pin, 2.5 x 2.5 x 0.8 mm) package (MSL3, 260 °C per JEDEC J-STD-020)



Skyworks Green™ products are compliant with all applicable legislation and are halogen-free. For additional information, refer to *Skyworks Definition of Green™*, document number SQ04-0074.

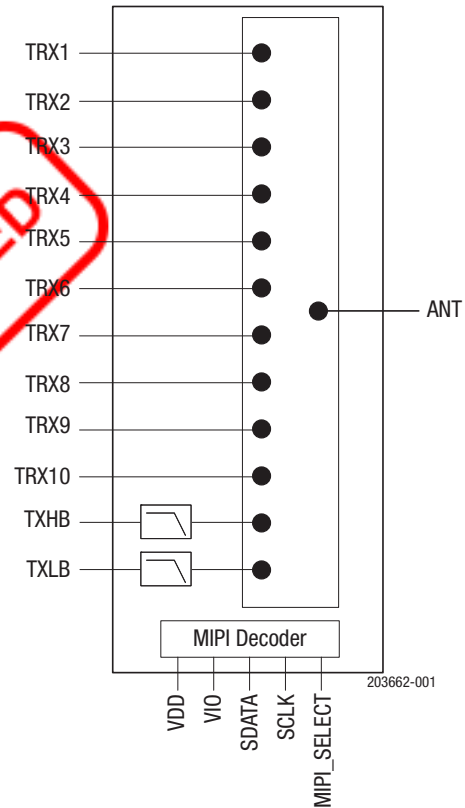

Figure 1. SKY13488-31 Block Diagram

Description

The SKY13488-31 is a single-pole, twelve-throw (SP12T) antenna switch with an integrated Mobile Industry Processor Interface (MIPI) controller. Using an advanced switching technology, the SKY13488-31 maintains low insertion and high isolation, which makes it an ideal choice for UMTS, CDMA2000, EDGE, GSM, and LTE applications.

The design features two dedicated GSM transmit ports and three dedicated ultra low-loss TRX ports. The switch also has an excellent triple beat ratio and second/third order intermodulation distortion (IMD2/IMD3) performance.

Switching is controlled by the MIPI decoder. There is an external MIPI select pin that enables how the switch responds to power mode triggers. When this pin is grounded, the switch responds to any of the power mode triggers. When this pin is left open, the switch responds to individual power mode triggers.

No external DC blocking capacitors are required on the RF paths as long as no DC voltage is applied.

The SKY13488-31 is manufactured in a compact, 2.5 x 2.5 x 0.8 mm, 20-pin surface mount Multi-Chip Module (MCM) package.

A functional block diagram is shown in Figure 1. The pin configuration and package are shown in Figure 2. Signal pin assignments and functional pin descriptions are provided in Table 1.

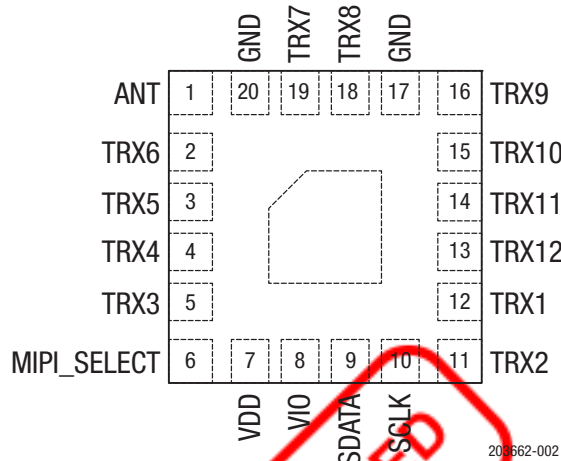

Figure 2. SKY13488-31 Pinout (Top View)

Table 1. SKY13488-31 Signal Descriptions¹

Pin	Name	Description	Pin	Name	Description
1	ANT	Antenna port	11	TRX2	Ultra low-loss 3G WCDMA transmit/receive port 2. This pin is either connected directly to or disconnected from pin 1, depending on the applied control data.
2	TRX6	3G WCDMA transmit/receive port 6. This pin is either connected directly to or disconnected from pin 1, depending on the applied control data.	12	TRX1	Ultra low-loss 3G WCDMA transmit/receive port 1. This pin is either connected directly to or disconnected from pin 1, depending on the applied control data.
3	TRX5	3G WCDMA transmit/receive port 5. This pin is either connected directly to or disconnected from pin 1, depending on the applied control data.	13	TRX10	3G WCDMA transmit/receive port 10. This pin is either connected directly to or disconnected from pin 1, depending on the applied control data.
4	TRX4	Ultra low-loss 3G WCDMA transmit/receive port 4. This pin is either connected directly to or disconnected from pin 1, depending on the applied control data.	14	TRX9	3G WCDMA transmit/receive port 9. This pin is either connected directly to or disconnected from pin 1, depending on the applied control data.
5	TRX3	Ultra low-loss 3G WCDMA transmit/receive port 3. This pin is either connected directly to or disconnected from pin 1, depending on the applied control data.	15	TRX8	3G WCDMA transmit/receive port 8. This pin is either connected directly to or disconnected from pin 1, depending on the applied control data.
6	MIPI_SELECT	MIPI interface select. When this pin is grounded, the switch responds to any of the power mode triggers. When this pin is left open, the switch is RFFE MIPI compliant and responds to individual power mode triggers.	16	TRX7	3G WCDMA transmit/receive port 7. This pin is either connected directly to or disconnected from pin 1, depending on the applied control data.
7	VDD	DC power supply	17	GND	Ground
8	VIO	MIPI decoder enable/reference voltage	18	TXHB	GSM transmit high band. This pin is either connected directly to or disconnected from pin 1, depending on the applied control data.
9	SDATA	Data input/output	19	TXLB	GSM transmit low band. This pin is either connected directly to or disconnected from pin 1, depending on the applied control data.
10	SCLK	Clock signal	20	GND	Ground

¹ Bottom ground paddles must be connected to ground.

Electrical and Mechanical Specifications

The absolute maximum ratings of the SKY13488-31 are provided in Table 2. Electrical specifications are provided in Tables 3 and 4.

IMD2 and IMD3 test conditions for various frequencies are listed in Tables 5 and 6, respectively.

Triple beat ratio (TBR) test conditions for bands 2 and 5 are listed in Table 7.

Figure 3 shows a timing diagram. Figure 4 illustrates the test setup used to measure intermodulation products. This industry standardized test is used to simulate the WCDMA Band 1 linearity of the antenna switch. A +20 dBm continuous wave (CW) signal, f_{FUND} , is sequentially applied to the TRX1 through TRX10 ports, while a -15 dBm CW blocker signal, f_{BLK} , is applied to the ANT port.

The resulting third order intermodulation distortion (IMD3), f_{RX} , is measured over all phases of f_{FUND} . The SKY13488-31 exhibits exceptional performance for all TRXx ports.

Table 8 shows the isolation matrix for “On” arms to “Off” arms. Table 9 shows the isolation matrix for “Ant” to “Off” arms. Table 10 provides the matrix of insertion loss and return loss information. Table 11 describes the register content and programming read/write sequences. Refer to the *MIPI Alliance Specification for RF Front-End Control Interface (RFFE)*, v1.10 (26 July 2011) for additional information on MIPI programming sequences and MIPI bus specifications.

Figures 5 and 6 provide the timing diagrams for register write commands and read commands, respectively.

Table 12 provides the Register_0 logic. Table 13 describes the register parameters and bit values.

Table 2. SKY13488-31 Absolute Maximum Ratings¹

Parameter	Symbol	Minimum	Maximum	Units
Supply voltage	VDD	2.5	6.0	V
MIPI decoder enable/reference voltage	VIO		2	V
Clock signal voltage	SCLK		VIO	V
Data signal voltage	SDATA		VIO	V
RF input power:	PIN			
LTX pin			+36	dBm
HTX pin			+34	dBm
all TRXx pins			+31	dBm
Storage temperature	TSTG	-55	+150	°C
Operating temperature	TOP	-30	+90	°C

¹ Exposure to maximum rating conditions for extended periods may reduce device reliability. There is no damage to device with only one parameter set at the limit and all other parameters set at or below their nominal value. Exceeding any of the limits listed here may result in permanent damage to the device.

ESD HANDLING: *Although this device is designed to be as robust as possible, electrostatic discharge (ESD) can damage this device. This device must be protected at all times from ESD when handling or transporting. Static charges may easily produce potentials of several kilovolts on the human body or equipment, which can discharge without detection. Industry-standard ESD handling precautions should be used at all times.*

Table 3. SKY13488-31 DC Electrical Specifications¹
(V_{DD} = 2.85 V, T_{OP} = +25 °C, Characteristic Impedance [Z₀] = 50 Ω, Unless Otherwise Noted)

Parameter	Symbol	Test Condition	Min	Typical	Max	Units
Supply voltage	V _{DD}		2.50	2.85	6.00	V
Supply current, active mode	I _{DD}			50	100	μA
Supply current, low power mode	I _{DD_L}			10		μA
Interface supply voltage	V _{IO}		1.65	1.80	1.95	V
Interface signal:	SDATA					
High			0.8 × V _{IO}			V
Low					0.2 × V _{IO}	V
Control current:						
High				1	5	μA
Low				1	5	μA

¹ Performance is guaranteed only under the conditions listed in this table.

Table 4. SKY13488-31 RF Electrical Specifications¹ (1 of 2)
(V_{DD} = 2.85 V, T_{OP} = +25 °C, Characteristic Impedance [Z₀] = 50 Ω, Unless Otherwise Noted)

Parameter	Symbol	Test Condition	Min	Typical	Max	Units
Operating frequency	f		0.7		2.7	GHz
Insertion loss	IL	TXLB, 824 to 915MHz		1.0	1.2	dB
		TXHB, 1710 to 1910 MHz		1.25	1.45	dB
		TRX1 to TRX10 ports: 700 to 824MHz		0.6	0.8	dB
		824 to 960 MHz		0.62	0.85	dB
		1710 to 1990 MHz		0.75	0.9	dB
		TRX4 to TRX10 ports: 2110 to 2170 MHz		0.8	0.95	dB
		TRX4 to TRX10 ports (except TRX6): 2300 to 2690 MHz		0.95	1.25	dB
GSM LB TX:	H2LB	2f0 attenuation 1830 MHz	20	23		dB
H4LB	4f0 attenuation 3660 MHz					dB
H3HB	3f0 attenuation 5730 MHz	25	28		dB	

Table 4. SKY13488-31 RF Electrical Specifications¹ (2 of 2)
(V_{DD} = 2.85 V, T_{OP} = +25 °C, Characteristic Impedance [Z₀] = 50 Ω, Unless Otherwise Noted)

Parameter	Symbol	Test Condition	Min	Typical	Max	Units
Isolation	ISO	TRx 1, 2, 7, 8, 9, 10 ports to TRx 3, 4, 5, 6 ports: 824 to 1910 MHz 1910 to 2690 MHz	32 25	35 30		dB dB
		Tx LB to any TRx/Rx ports: 824 to 960 MHz	35	36		dB
		Tx HB to any TRx/Rx ports: 1710 to 1910 MHz	30	32		dB
		Any adjacent ports: 824 to 1910 MHz 1910 to 2690 MHz	20 17	23 19		dB dB
		Any non-adjacent ports: 824 to 1910 MHz 1910 to 2690 MHz	25 20	28 23		dB dB
		Antenna to any TRx ports: 824 to 1910 MHz 1910 to 2690 MHz	30 23	32 26		dB dB
		Tx LB to Tx HB when TX HB is on: 1648 to 1830 MHz	27	28.5		dB
Return loss	IS11I	0.7 to 2.7 GHz	14	18		dB
GSM harmonics: High band Low band	2fo, 3fo	PIN = +33 dBm, 50 Ω PIN = +33 dBm, 3:1 VSWR		-53 -41	-40	dBm dBm
		PIN = +35 dBm, 50 Ω PIN = +35 dBm, 3:1 VSWR		-50 -36	-45	dBm dBm
TRXx harmonics	2fo, 3fo	PIN = +27 dBm, 50 Ω, f = 704 to 2700 MHz		-68	-62	dBm
		PIN = +27 dBm, 5:1 VSWR, f = 704 to 2700 MHz		-58	-50	dBm
TRX1 through TRX10, band 13 2 nd harmonics	2fo	PIN = +25 dBm f = 787 MHz		-81		dBm
Second order intermodulation distortion	IMD2	See test conditions in Table 5		-110	-105	dBm
Third order intermodulation distortion	IMD3	See test conditions in Table 6		-110	-105	dBm
Triple beat ratio: 650 to 900 MHz 1710 to 2155 MHz	TBR	See test conditions in Table 7	+81 +81			dBc dBc
Turn-on time	t _{ON}	From application of V _{DD} and V _{IO}			20	μs
Switching speed	t _s	Port to port		2	5	μs

¹ Performance is guaranteed only under the conditions listed in this table.

Table 5. IMD2 Test Conditions

Band	Transmit Frequency (MHz)	Transmit Power (dBm)	Frequency Blocker, Low (MHz)	Frequency Blocker, High (MHz)	Power Blocker (dBm)	Receive Frequency (MHz)
1	1950.0	+20	190	4090	-15	2140.0
2	1880.0		80	3840		1960.0
4	1732.0		400	3864		2132.0
5	836.5		45	1718		881.5
7	2535.0		120	5187		2655.0
8	897.0		45	1839		942.0

Table 6. IMD3 Test Conditions

Band	Transmit Frequency (MHz)	Transmit Power (dBm)	Frequency Blocker (MHz)	Power Blocker (dBm)	Receive Frequency (MHz)
1	1950.0	+20	1760.0	-15	2140.0
2	1880.0		1800.0		1960.0
4	1732.0		1332.0		2132.0
5	836.5		791.5		881.5
7	2535.0		2415.0		2655.0
8	897.0		852.0		942.0

Table 7. Triple Beat Ratio Test Conditions

Band	Transmit Frequency 1 (MHz)	Transmit Power 1 (dBm)	Transmit Frequency 2 (MHz)	Transmit Power 2 (dBm)	Frequency Blocker @ ANT (MHz)	Power Blocker (dBm)	TBR Product Frequency (MHz)
2	1880.0	+21.5	1881.0	+21.5	1960.0	-30	1960.0 ± 1
5	836.5		881.5		881.5		881.5 ± 1

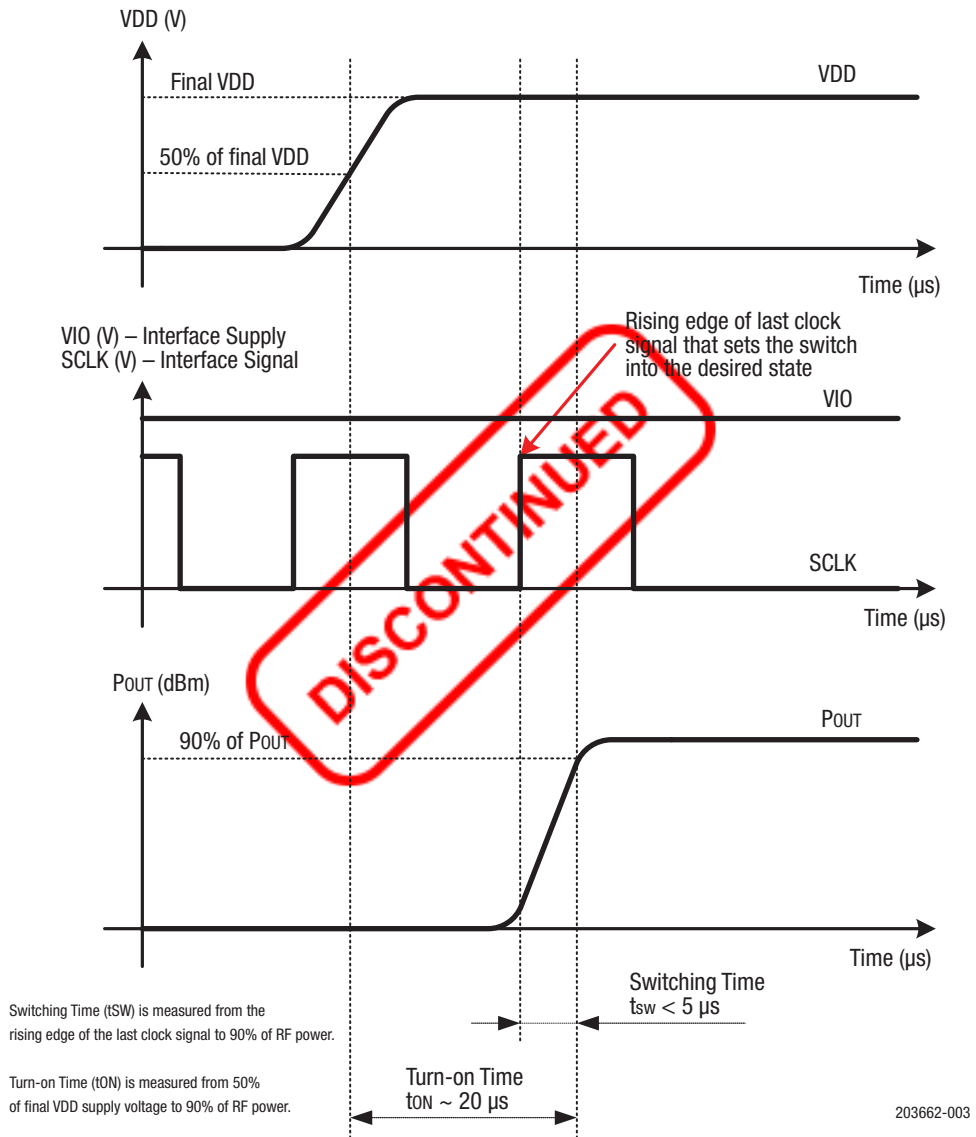

Figure 3. SKY13488-31 Timing Diagram

Table 8. SKY13488-31: Isolation Matrix: Isolation “On” Arms to “Off” Arms

		Isolation (dB)											
ON_Throw	freq (GHz)	TXLB	TXHB	TRX1	TRX2	TRX3	TRX4	TRX5	TRX6	TRX7	TRX8	TRX9	TRX10
TXLB	0.915		-36	-49	-50	-47	-44	-42	-45	-48	-50	-50	-51
TXLB	1.91		-33	-49	-54	-46	-43	-59	-42	-40	-42	-45	-48
TXLB	2.69		-21	-44	-49	-43	-39	-45	-42	-38	-40	-43	-45
TXHB	0.915	-35		-45	-48	-54	-54	-50	-47	-43	-36	-40	-43
TXHB	1.91	-27		-37	-39	-43	-42	-40	-38	-37	-29	-33	-36
TXHB	2.69	-21		-37	-38	-42	-41	-40	-40	-34	-28	-34	-37
TRX1	0.915	-32	-45		-35	-52	-55	-52	-49	-49	-45	-42	-35
TRX1	1.91	-35	-36		-28	-42	-43	-42	-38	-40	-38	-35	-28
TRX1	2.69	-31	-36		-24	-36	-36	-37	-34	-35	-35	-31	-24
TRX2	0.915	-32	-46	-35		-50	-54	-53	-49	-50	-47	-44	-38
TRX2	1.91	-34	-36	-27		-41	-43	-41	-38	-41	-40	-37	-31
TRX2	2.69	-30	-36	-23		-35	-36	-37	-33	-36	-36	-33	-27
TRX3	0.915	-30	-47	-49	-46		-30	-37	-39	-53	-56	-53	-52
TRX3	1.91	-31	-37	-40	-38		-23	-29	-30	-43	-47	-45	-44
TRX3	2.69	-29	-35	-37	-34		-19	-25	-26	-37	-42	-41	-40
TRX4	0.915	-31	-46	-49	-47	-35		-30	-37	-53	-55	-53	-52
TRX4	1.91	-33	-36	-41	-39	-28		-23	-28	-43	-46	-45	-44
TRX4	2.69	-31	-35	-36	-34	-24		-19	-24	-37	-42	-41	-40
TRX5	0.915	-32	-45	-49	-48	-39	-34		-30	-52	-54	-52	-51
TRX5	1.91	-36	-36	-40	-39	-31	-27		-23	-42	-45	-44	-43
TRX5	2.69	-33	-36	-36	-34	-27	-23		-19	-37	-41	-40	-39
TRX6	0.915	-35	-43	-49	-49	-41	-39	-36		-51	-52	-51	-51
TRX6	1.91	-43	-35	-40	-39	-33	-31	-28		-41	-43	-43	-43
TRX6	2.69	-34	-37	-35	-34	-28	-27	-24		-36	-39	-38	-38
TRX7	0.915	-34	-45	-44	-47	-55	-55	-51	-49		-30	-35	-41
TRX7	1.91	-47	-36	-36	-39	-43	-43	-42	-38		-23	-29	-35
TRX7	2.69	-36	-36	-32	-34	-37	-37	-37	-34		-20	-26	-32
TRX8	0.915	-33	-43	-42	-46	-55	-55	-51	-49	-37		-30	-38
TRX8	1.91	-41	-36	-34	-38	-43	-43	-42	-38	-29		-23	-32
TRX8	2.69	-35	-41	-30	-34	-37	-37	-37	-34	-25		-20	-29
TRX9	0.915	-33	-42	-38	-44	-55	-55	-51	-49	-40	-34		-31
TRX9	1.91	-38	-34	-31	-37	-43	-43	-42	-38	-33	-27		-25
TRX9	2.69	-34	-35	-28	-33	-37	-37	-37	-34	-29	-24		-22
TRX10	0.915	-32	-44	-30	-38	-54	-55	-52	-49	-47	-42	-37	
TRX10	1.91	-36	-35	-23	-30	-43	-43	-42	-38	-39	-35	-30	
TRX10	2.69	-32	-36	-19	-26	-37	-37	-37	-34	-34	-32	-27	

Table 9. SKY13488-31: Isolation Matrix “ANT” to “Off” Arms

		Isolation (dB)											
ON_Throw	freq (GHz)	TXLB	TXHB	TRX1	TRX2	TRX3	TRX4	TRX5	TRX6	TRX7	TRX8	TRX9	TRX10
ANT	0.915		-37	-47	-47	-43	-41	-40	-36	-45	-46	-47	-47
ANT	1.91		-40	-42	-42	-33	-29	-28	-30	-41	-43	-43	-44
ANT	2.69		-38	-44	-46	-33	-29	-27	-32	-45	-45	-46	-46
ANT	0.915	-52		-51	-48	-46	-44	-41	-38	-43	-41	-50	-54
ANT	1.91	-28		-38	-37	-39	-37	-35	-31	-33	-30	-36	-39
ANT	2.69	-24		-30	-29	-31	-30	-30	-26	-29	-24	-29	-31
ANT	0.915	-41	-39		-43	-47	-45	-42	-38	-48	-52	-52	-45
ANT	1.91	-32	-34		-32	-39	-37	-35	-32	-39	-42	-41	-34
ANT	2.69	-30	-38		-27	-36	-34	-32	-28	-35	-38	-36	-29
ANT	0.915	-40	-39	-44		-49	-45	-42	-39	-47	-51	-53	-48
ANT	1.91	-32	-34	-33		-39	-37	-36	-32	-39	-42	-42	-37
ANT	2.69	-29	-38	-28		-35	-34	-32	-28	-35	-37	-37	-32
ANT	0.915	-38	-39	-48	-50		-38	-45	-38	-46	-46	-47	-48
ANT	1.91	-30	-34	-37	-38		-29	-33	-29	-39	-39	-40	-40
ANT	2.69	-28	-39	-33	-34		-25	-28	-25	-35	-36	-36	-37
ANT	0.915	-39	-39	-47	-49	-43		-39	-40	-46	-46	-47	-48
ANT	1.91	-31	-35	-38	-39	-32		-30	-30	-39	-39	-40	-41
ANT	2.69	-29	-39	-34	-35	-27		-25	-25	-35	-37	-37	-37
ANT	0.915	-43	-39	-48	-49	-44	-43		-39	-46	-47	-47	-48
ANT	1.91	-33	-35	-39	-39	-34	-32		-28	-39	-40	-40	-41
ANT	2.69	-30	-41	-35	-35	-29	-27		-23	-35	-37	-37	-37
ANT	0.915	-44	-40	-48	-48	-43	-43	-42		-47	-48	-48	-49
ANT	1.91	-36	-35	-39	-39	-34	-34	-31		-39	-40	-40	-41
ANT	2.69	-30	-44	-34	-34	-29	-29	-26		-35	-37	-37	-37
ANT	0.915	-46	-34	-52	-48	-46	-44	-41	-38		-38	-48	-53
ANT	1.91	-38	-28	-41	-38	-39	-37	-35	-31		-30	-38	-43
ANT	2.69	-32	-29	-36	-33	-35	-33	-32	-28		-26	-32	-38
ANT	0.915	-45	-36	-52	-49	-46	-44	-41	-38	-41		-38	-45
ANT	1.91	-36	-31	-42	-38	-39	-37	-35	-31	-32		-31	-38
ANT	2.69	-32	-35	-36	-33	-35	-34	-32	-28	-27		-27	-35
ANT	0.915	-43	-38	-45	-48	-46	-44	-41	-38	-44	-46		-36
ANT	1.91	-35	-32	-39	-37	-39	-37	-35	-31	-34	-35		-30
ANT	2.69	-31	-36	-35	-32	-35	-34	-32	-28	-30	-29		-27
ANT	0.915	-41	-39	-38	-41	-47	-44	-42	-38	-48	-52	-47	
ANT	1.91	-33	-34	-30	-30	-39	-37	-35	-32	-39	-41	-37	
ANT	2.69	-30	-39	-26	-25	-35	-34	-32	-28	-35	-36	-32	

Table 10. SKY13488-31: Insertion Loss and Return Loss Matrix

ON_Throw	freq (GHz)	IL (dB)	RL_pole (dB)	RL_throw (dB)
LB	0.915	-1.0	-21.7	-15.3
HB	1.91	-1.2	-17.0	-11.9
TRX1	0.915	-0.5	-31.7	-26.0
TRX1	1.91	-0.7	-32.8	-23.5
TRX1	2.69	-0.8	-28.3	-21.1
TRX2	0.915	-0.5	-33.2	-25.7
TRX2	1.91	-0.7	-27.5	-25.3
TRX2	2.69	-0.8	-28.8	-26.9
TRX3	0.915	-0.5	-26.3	-25.6
TRX3	1.91	-0.7	-20.9	-25.0
TRX3	2.69	-0.9	-17.7	-20.3
TRX4	0.915	-0.5	-23.5	-24.0
TRX4	1.91	-0.7	-18.1	-18.8
TRX4	2.69	-0.9	-16.1	-17.3
TRX5	0.915	-0.5	-21.4	-22.3
TRX5	1.91	-0.8	-16.0	-16.2
TRX5	2.69	-1.0	-13.8	-14.7
TRX6	0.915	-0.6	-20.6	-20.8
TRX6	1.91	-0.8	-13.9	-14.8
TRX6	2.69	-1.3	-10.7	-11.3
TRX7	0.915	-0.5	-28.4	-26.2
TRX7	1.91	-0.7	-25.4	-23.3
TRX7	2.69	-0.8	-22.5	-22.6
TRX8	0.915	-0.5	-26.1	-25.3
TRX8	1.91	-0.7	-23.7	-19.6
TRX8	2.69	-0.8	-22.0	-19.5
TRX9	0.915	-0.5	-28.5	-23.8
TRX9	1.91	-0.6	-25.1	-22.1
TRX9	2.69	-0.8	-20.4	-19.2
TRX10	0.915	-0.5	-29.3	-25.0
TRX10	1.91	-0.7	-29.9	-22.3
TRX10	2.69	-0.8	-23.8	-20.2

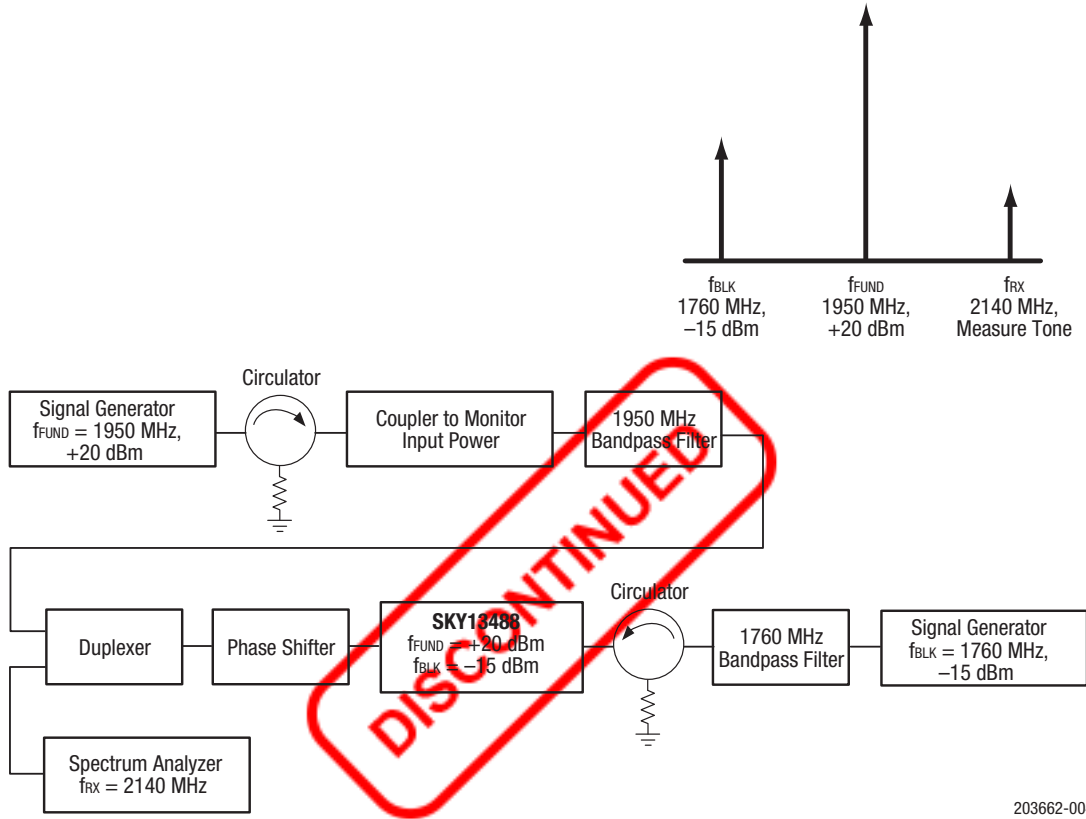

Figure 4. Third Order Intermodulation Test Setup

203662-004

Table 11. Command Sequence Bit Definitions

Type	SSC	C11-C8	C7	C6-C5	C4	C3-C0	Parity Bits	BPC	Extended Operation					
									DA7(1) - DA0(1)	Parity Bits	BPC	DA7(n) - DA0(n)	Parity Bits	BPC
Reg0 Write	Y	SA[3:0]	1	Data[6:5]	Data[4]	Data[3:0]	Y	Y	-	-	-	-	-	-
Reg Write	Y	SA[3:0]	0	10	Addr[4]	Addr[3:0]	Y	-	Data[7:0]	-	-	-	Y	Y
Reg Read	Y	SA[3:0]	0	11	Addr[4]	Addr[3:0]	Y	Y	Data[7:0]	-	-	-	Y	Y

Legend:

SSC = Sequence start command DA = Data/address frame bits BC = Byte count (# of consecutive addresses)
 C = Command frame bits BPC = Bus park cycle

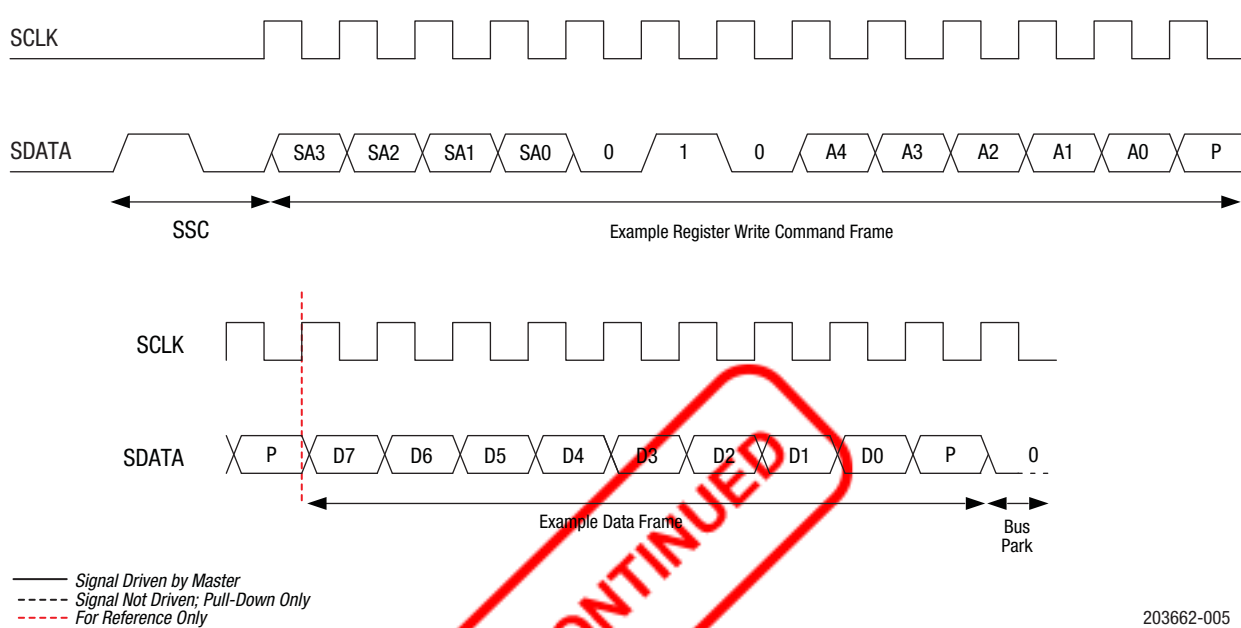

203662-005

Figure 5. Register Write Command Timing Diagram

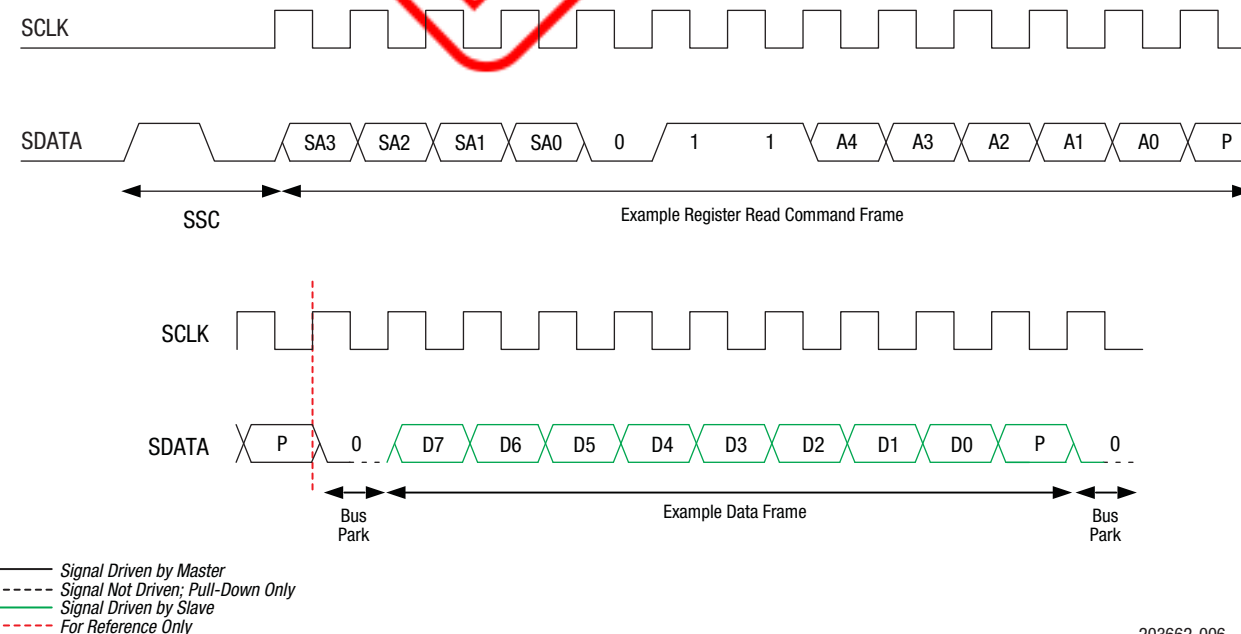
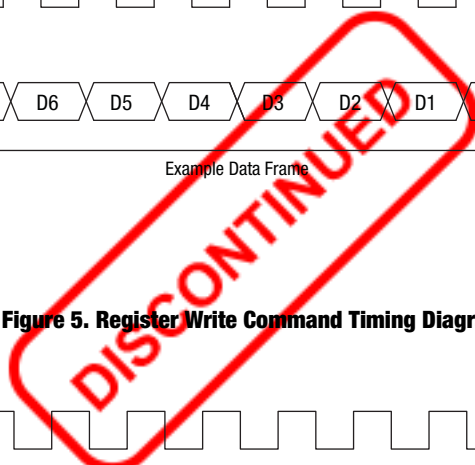

203662-006

Figure 6. Register Read Command Timing Diagram

Table 12. Register_0 Truth Table

Antenna Path	Register_0 Bits							
	Bit[7]	Bit[6]	Bit[5]	Bit[4]	Bit[3]	Bit[2]	Bit[1]	Bit[0]
Sleep mode (standby)	X	0	0	0	0	0	0	0
2G transmit low band	X	0	0	0	1	0	1	0
2G transmit high band	X	0	0	0	1	0	0	0
TRX1	X	0	0	0	0	1	0	0
TRX2	X	0	0	0	0	1	0	1
TRX3	X	0	0	0	0	1	1	0
TRX4	X	0	0	0	0	1	1	1
TRX5	X	0	0	0	1	0	0	1
TRX6	X	0	0	0	1	0	1	1
TRX7	X	0	0	0	1	1	0	0
TRX8	X	0	0	0	0	0	0	1
TRX9	X	0	0	0	0	0	1	0
TRX10	X	0	0	0	0	0	1	1
Isolation mode (warm-up)	X	1	1	1	1	1	1	1

Table 13. Register Description and Programming (1 of 3)

Register		Parameter	Description	Default (Binary)
Name	Address (Hex)			
Register_0	0000	MODE_CTRL	Bits[7:0]: Switch control. See Table 8 for logic	-
RFFE_STATUS	001A	SOFTWARE_RESET	Bit[7]: Resets all data to default values except for USID, GSID, or the contents of the PM_TRIG Register. 0 = Normal operation 1 = Software reset	0
		COMMAND_FRAME_PARITY_ERR	Bit[6]: Command sequence received with parity error - discard command.	0
		COMMAND_LENGTH_ERR	Bit[5]: Command length error.	0
		ADDRESS_FRAME_PARITY_ERR	Bit[4]: Address frame parity error =1.	0
		DATA_FRAME_PARITY_ERR	Bit[3]: Data frame with parity error.	0
		READ_UNUSED_REG	Bit[2]: Read command to an invalid address.	0
		WRITE_UNUSED_REG	Bit[1]: Write command to an invalid address.	0
		BID_GID_ERR	Bit[0]: Read command with a BROADCAST_ID (refer to the <i>MIPI Alliance Specification</i>) or GSID.	0

Table 13. Register Description and Programming (2 of 3)

Register		Parameter	Description	Default (Binary)
Name	Address (Hex)			
GROUP_SID	001B	Reserved	Bits[7:4]: Reserved	0000
		GSID	Bits[3:0]: Group slave ID	0000
PM_TRIG ¹	001C	PWR_MODE	Bits[7:6]: 00 = Normal operation (active) 01 = Default settings (startup) 10 = Low power (low power) 11 = Reserved	01
		Trigger_Mask_2	Bit[5]: If this bit is set, trigger 2 is disabled. When all triggers are disabled, if writing to a register that is associated with trigger 2, the data goes directly to the destination register.	0
		Trigger_Mask_1	Bit[4]: If this bit is set, trigger 1 is disabled. When all triggers are disabled, if writing to a register that is associated with trigger 1, the data goes directly to the destination register.	0
		Trigger_Mask_0	Bit[3]: If this bit is set, trigger 0 is disabled. When all triggers are disabled, if writing to a register that is associated with trigger 0, the data goes directly to the destination register.	0
		Trigger_2	Bit[2]: If this bit is set, data is loaded into the trigger 2 registers.	0
		Trigger_1	Bit[1]: If this bit is set, data is loaded into the trigger 1 registers (unsupported).	0
		Trigger_0	Bit[0]: If this bit is set, data is loaded into the trigger 0 registers (unsupported).	0
PRODUCT_ID	001D	PRODUCT_ID	Bits[7:0]: This is a read-only register. However, during the programming of the Unique Slave Identifier (USID), a write command sequence is performed on this register but the value is not changed.	01011111

Table 13. Register Description and Programming (3 of 3)

Register		Parameter	Description	Default (Binary)
Name	Address (Hex)			
MANUFACTURER_ID	001E	MANUFACTURER_ID	Bits[7:0]: Read-only register	10100101
MAN_USID	001F	Reserved	Bits[7:6]: Reserved	00
		MANUFACTURER_ID	Bits[5:4]: Read-only register	01
		USID	Bits[3:0]: Programmable USID. A write to these bits programs the USID.	1011

1 Unlike the complete independence between triggers 0, 1, and 2, and also between the associated trigger masks 0, 1, and 2, respectively, as described in the MIPI RFFE Specification, this device uses additional interactions between the provided trigger functions.

The delayed application of updated data to all triggerable registers in this device may be accomplished using any of the three triggers (0, 1, or 2), provided that the particular trigger used is not currently masked off. If multiple triggers are enabled, any or all of those are sufficient to cause the data to be transferred from shadow registers to destination registers for all triggerable registers in the device.

It is also necessary to disable all three triggers (i.e., set all three trigger masks) to ensure that data written to any triggerable register will immediately be written to the destination register at the conclusion of the RFFE command sequence where the data is written.

Evaluation Board Description

The SKY13488-31 Evaluation Board is used to test the performance of the SKY13488-31 SP12T Switch. An Evaluation Board schematic diagram is provided in Figure 7. A recommended ESD protection circuit diagram is provided in Figure 8. An assembly drawing for the Evaluation Board is shown in Figure 9.

Package Dimensions

The PCB layout footprint for the SKY13488-31 is provided in Figure 10. Typical case markings are shown in Figure 11. Package dimensions for the 20-pin MCM are shown in Figure 12, and tape and reel dimensions are provided in Figure 13.

Package and Handling Information

Since the device package is sensitive to moisture absorption, it is baked and vacuum packed before shipping. Instructions on the shipping container label regarding exposure to moisture after the container seal is broken must be followed. Otherwise, problems related to moisture absorption may occur when the part is subjected to high temperature during solder assembly.

The SKY13488-31 is rated to Moisture Sensitivity Level 3 (MSL3) at 260 °C. It can be used for lead or lead-free soldering. For additional information, refer to the Skyworks Application Note, *PCB Design and SMT Assembly/Rework Guidelines for MCM-L Packages*, document number 101752.

Care must be taken when attaching this product, whether it is done manually or in a production solder reflow environment. Production quantities of this product are shipped in a standard tape and reel format.

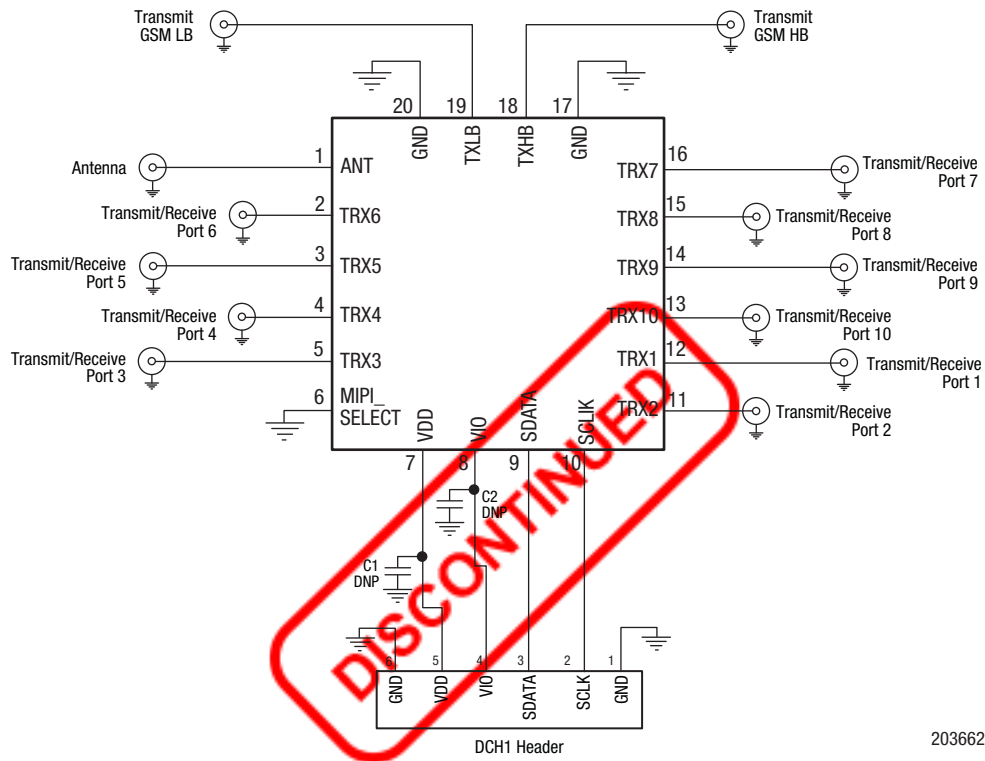

203662-007

Figure 7. SKY13488-31 Evaluation Board Schematic

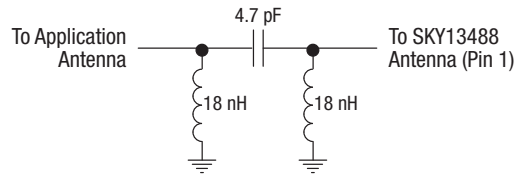

ESD Circuit 1

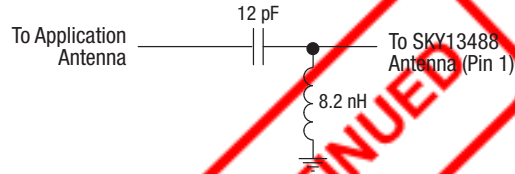

ESD Circuit 2

203662-008

Figure 8. SKY13488-31 Recommended ESD Protection Circuits

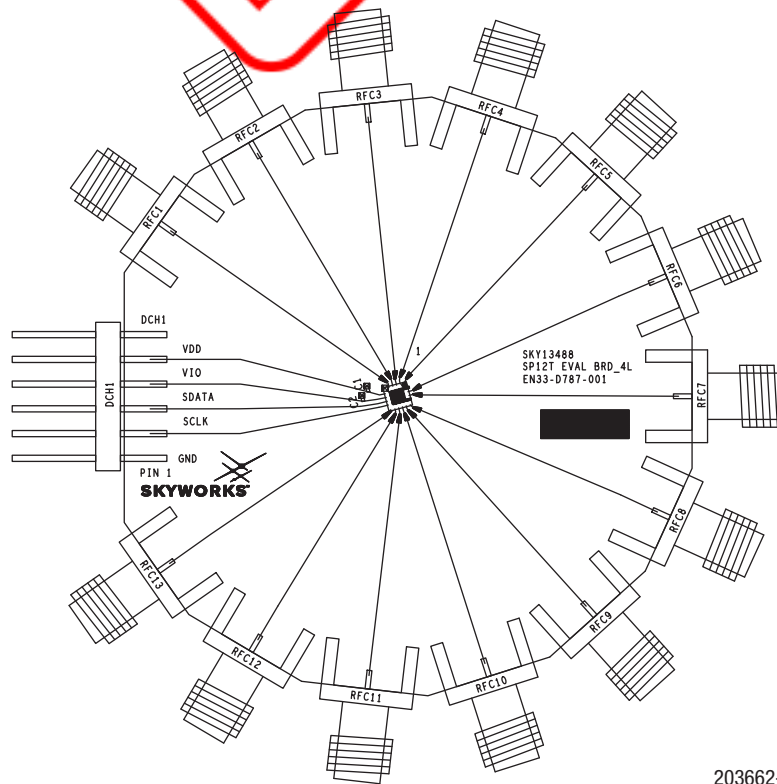

203662-009

Figure 9. SKY13488-31 Evaluation Board Assembly Diagram

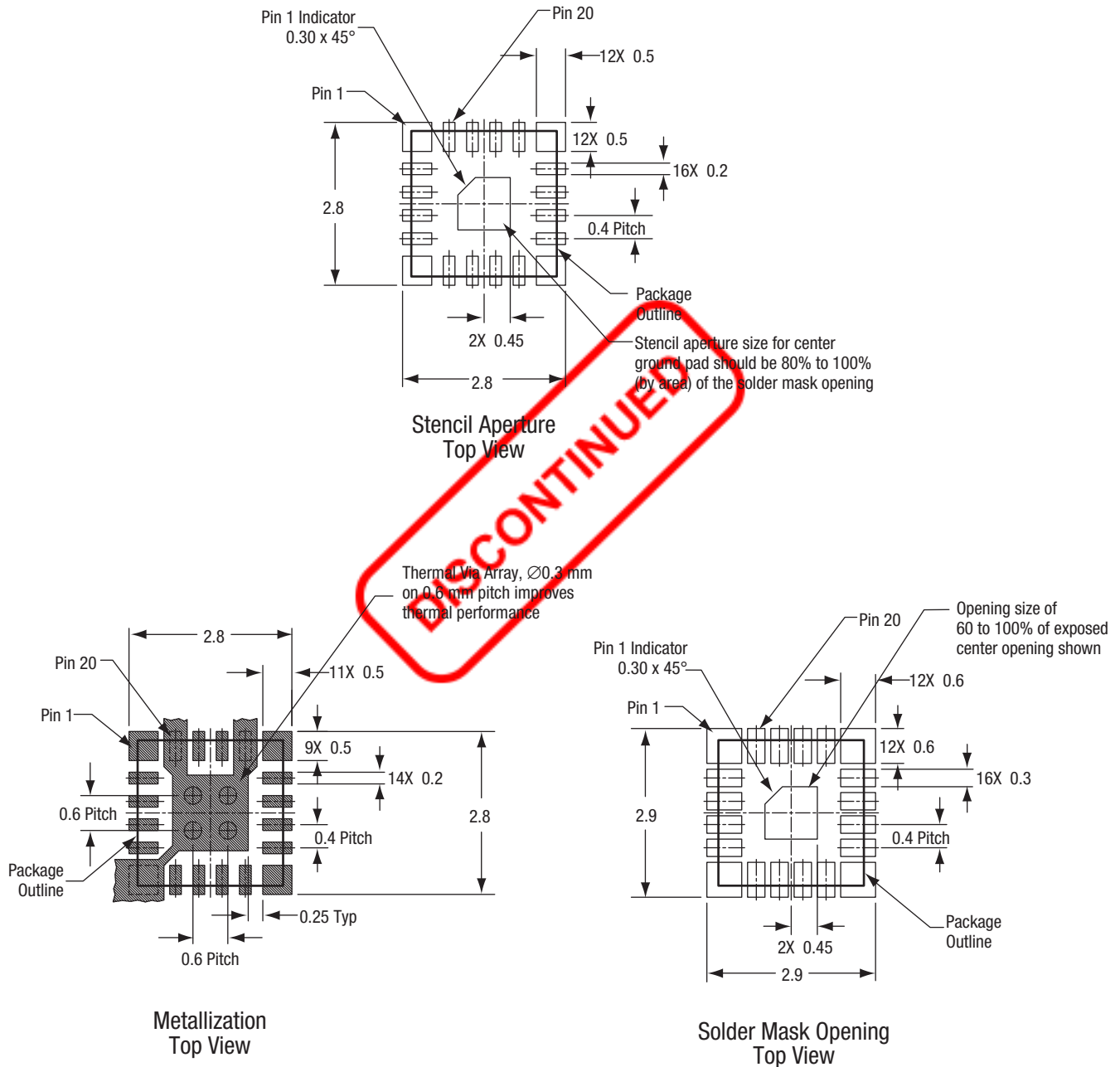

Notes:

1. All dimensions are in millimeters
2. Thermal vias should be resin filled and capped according to IPC-4761, Type VII vias.
3. Recommended Cu thickness is 30 to 35 μ m.

203662-010

Figure 10. SKY13488-31 PCB Layout Footprint (Top View)

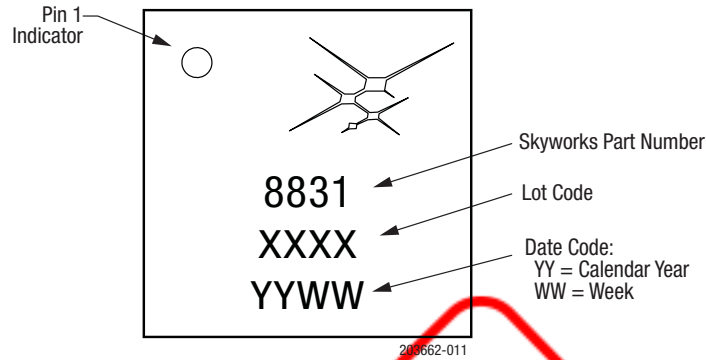
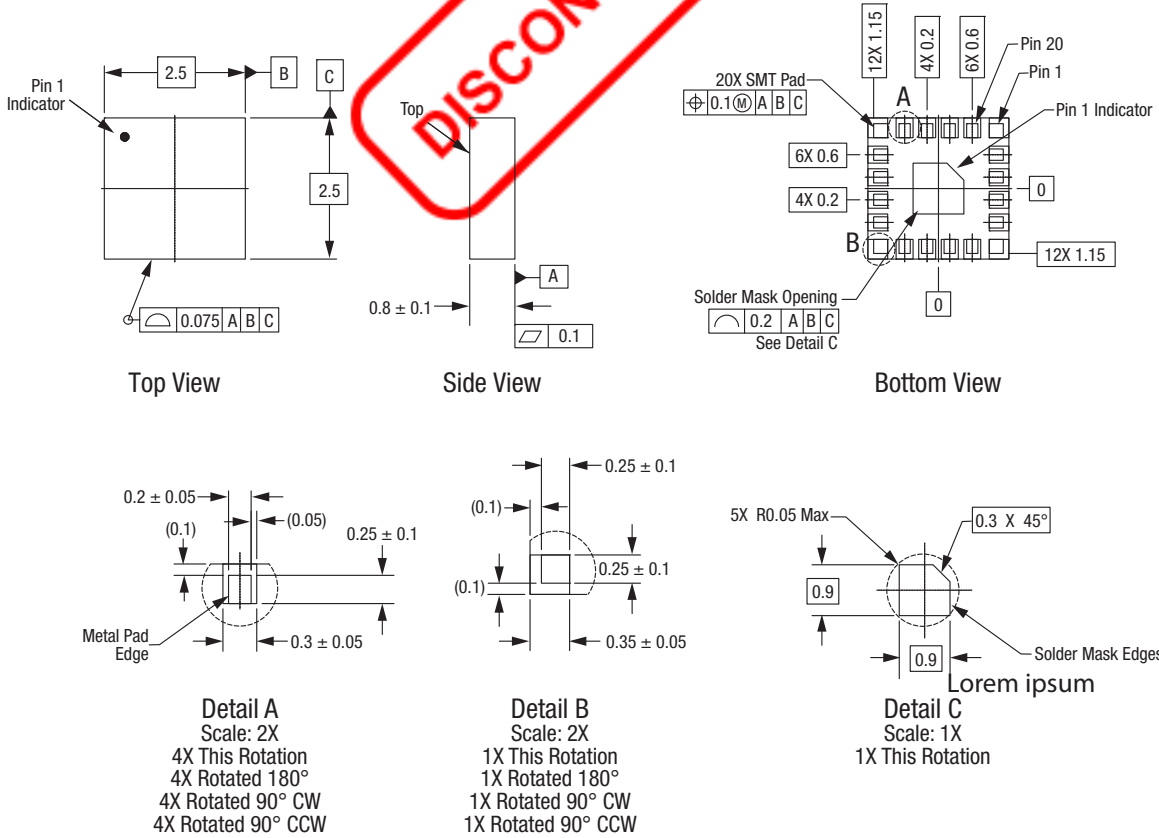

Figure 11. Typical Part Markings (Top View)



Notes:

1. Dimensions and tolerances according to ASME Y14.5M-1994.
2. All measurements are in millimeters.

203662-012

Figure 12. SKY13488-31 Package Dimensions

Ordering Information

Model Name	Manufacturing Part Number	Evaluation Board Part Number
SKY13488-31: 0.7 to 2.7 GHz SP12T Antenna Switch with MIPI Interface	SKY13488-31	SKY13488-31-EVB



Copyright © 2015, 2017 Skyworks Solutions, Inc. All Rights Reserved.

Information in this document is provided in connection with Skyworks Solutions, Inc. (“Skyworks”) products or services. These materials, including the information contained herein, are provided by Skyworks as a service to its customers and may be used for informational purposes only by the customer. Skyworks assumes no responsibility for errors or omissions in these materials or the information contained herein. Skyworks may change its documentation, products, services, specifications or product descriptions at any time, without notice. Skyworks makes no commitment to update the materials or information and shall have no responsibility whatsoever for conflicts, incompatibilities, or other difficulties arising from any future changes.

No license, whether express, implied, by estoppel or otherwise, is granted to any intellectual property rights by this document. Skyworks assumes no liability for any materials, products or information provided hereunder, including the sale, distribution, reproduction or use of Skyworks products, information or materials, except as may be provided in Skyworks Terms and Conditions of Sale.

THE MATERIALS, PRODUCTS AND INFORMATION ARE PROVIDED “AS IS” WITHOUT WARRANTY OF ANY KIND, WHETHER EXPRESS, IMPLIED, STATUTORY, OR OTHERWISE, INCLUDING FITNESS FOR A PARTICULAR PURPOSE OR USE, MERCHANTABILITY, PERFORMANCE, QUALITY OR NON-INFRINGEMENT OF ANY INTELLECTUAL PROPERTY RIGHT; ALL SUCH WARRANTIES ARE HEREBY EXPRESSLY DISCLAIMED. SKYWORKS DOES NOT WARRANT THE ACCURACY OR COMPLETENESS OF THE INFORMATION, TEXT, GRAPHICS OR OTHER ITEMS CONTAINED WITHIN THESE MATERIALS. SKYWORKS SHALL NOT BE LIABLE FOR ANY DAMAGES, INCLUDING BUT NOT LIMITED TO ANY SPECIAL, INDIRECT, INCIDENTAL, STATUTORY, OR CONSEQUENTIAL DAMAGES, INCLUDING WITHOUT LIMITATION, LOST REVENUES OR LOST PROFITS THAT MAY RESULT FROM THE USE OF THE MATERIALS OR INFORMATION, WHETHER OR NOT THE RECIPIENT OF MATERIALS HAS BEEN ADVISED OF THE POSSIBILITY OF SUCH DAMAGE.

Skyworks products are not intended for use in medical, lifesaving or life-sustaining applications, or other equipment in which the failure of the Skyworks products could lead to personal injury, death, physical or environmental damage. Skyworks customers using or selling Skyworks products for use in such applications do so at their own risk and agree to fully indemnify Skyworks for any damages resulting from such improper use or sale.

Customers are responsible for their products and applications using Skyworks products, which may deviate from published specifications as a result of design defects, errors, or operation of products outside of published parameters or design specifications. Customers should include design and operating safeguards to minimize these and other risks. Skyworks assumes no liability for applications assistance, customer product design, or damage to any equipment resulting from the use of Skyworks products outside of stated published specifications or parameters.

Skyworks and the Skyworks symbol are trademarks or registered trademarks of Skyworks Solutions, Inc., in the United States and other countries. Third-party brands and names are for identification purposes only, and are the property of their respective owners. Additional information, including relevant terms and conditions, posted at www.skyworksinc.com, are incorporated by reference.